



better together

Data sheet

DRG 300/2/80 E0ET5

GREY
series

Technical specification

3~ 50 Hz

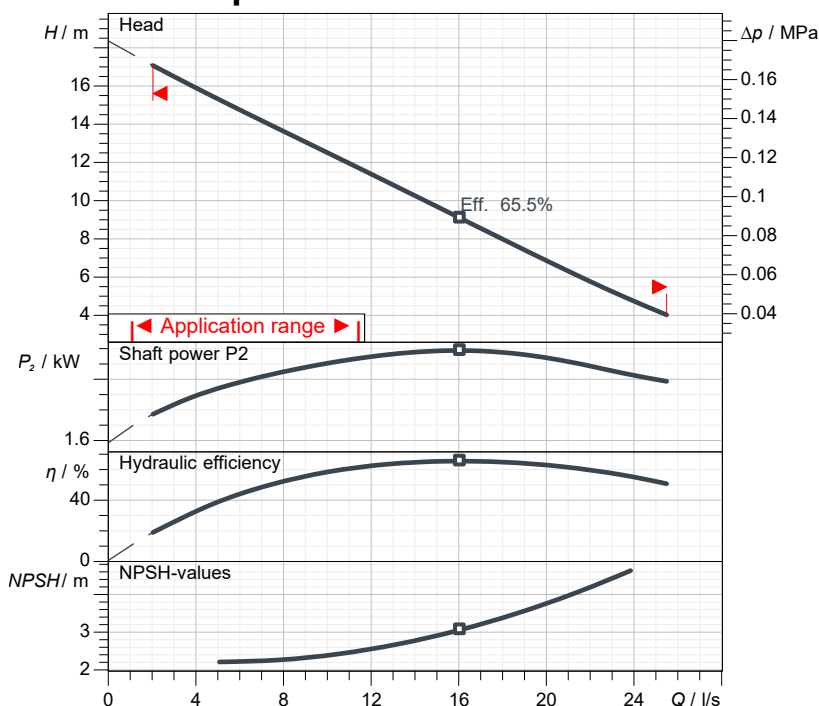

Characteristic curves according to UNI EN ISO 9906:2012
P2 < 10kW: paragraph 4.4.2
10kW < P2 < 100kW: Grade 3B
P2 > 100kW: Grade 2B

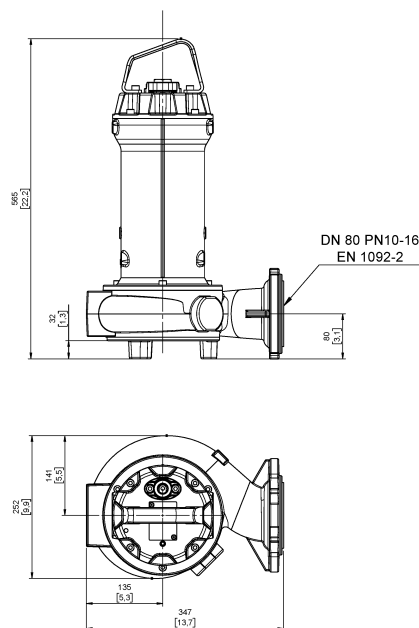

[mm
[inch]

Pump

Series	GREY series
Pump name	DRG 300/2/80 E0ET5
Configuration	NGTSB51040N00NN
Standard	CE

Operating limits (standard pumps)

Max. ambient temperature	40 °C
Max. density treated liquid	1100 kg/m ³
pH treated liquid	6 ÷ 14
Max. start per hour (equally distributed)	30
Wet/dry use	WET
Max. acoustic pressure level	70 dB
Operating mode	S1 - Continuous use

Motor data

Rated voltage	400 V
Frequency	50 Hz
Motor phases	3~
Number of poles	2
Rated power P2	2.20 kW
Incoming power P1	2.76 kW
Rated current	4.6 A
rpm	2880 1/min
Efficiency	79.7 %
cos φ	0.862
Rated torque	7.3 Nm
Start	Direct starting
Starting current	28.2 A
Degree of protection	IP 68
Insulation class	H
Capacitor	
Starting Capacitor	

Construction materials

Case	Cast iron EN-GJL 250
Shaft	Stainless steel AISI 431
Hydraulic	Cast iron EN-GJL 250
Impeller	Cast iron EN-GJL 250
Painting/Coating	Bi-epoxy 200 μm sea water
Screws	Stainless steel - Class A2-70
Gaskets	NBR

Construction features

Cooling system	No cooling jacket
Main cable	4G1,5 + 3x1
Cable length	10 mt
Mechanical seals	2 in silicon carbide (2SiC)
Additional drilling	-
Weight*	45.2 kg
Electrical variant	Thermal protection and leakage sensor

* cable and fixing system excluded

Hydraulic

Free passage	40 x 35 mm
Impeller type	Open channel impeller
Max. hydraulic efficiency	65.5 %
Suction	DN 80 UNDRILLED
Discharge	DN 80 EN 1092-2

Rev. 0 - 16-12-2014

All data shown are not binding. Zenit reserves the right to change data and dimensions without notice.

Created on 2021-11-12

zenit.com

Page 1 / 3



better together

Data sheet DRG 300/2/80 E0ET5

GREY
series

Pump performance curves

3~ 50 Hz

Impeller type Open channel impeller		Free passage 40 x 35 mm	Discharge DN 80	Suction DN 80	
DUTY POINT					
Flow	Head	Shaft power P2	Hydraulic efficiency	Density 998.3 kg/m ³	Viscosity 1.005 mm ² /s

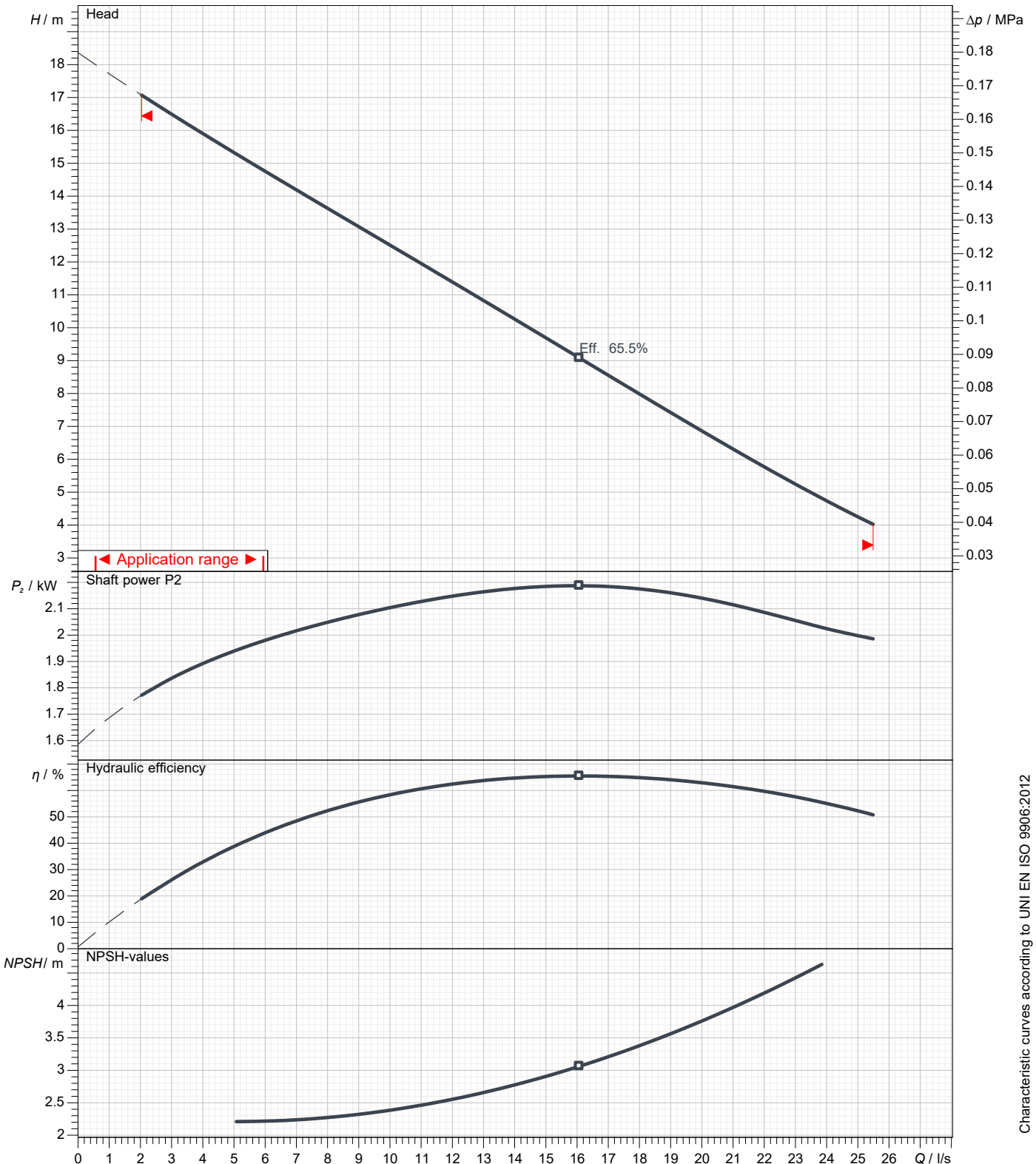

Characteristic curves according to UNI EN ISO 9906:2012
 P2<10kW: paragraph 4.4.2
 10kW<P2<100kW: Grade 3B
 P2>100kW: Grade 2B



better together

Data sheet DRG 300/2/80 E0ET5

GREY
series

Dimensional drawing

3~ 50 Hz

Installation type Installation with bottom coupling device - Vertical outlet		
Wet/dry use WET	Drilling variant N	Flushing valve - drilling -
Discharge DN 80 EN 1092-2	Suction DN 80 UNDRILLED	Pressure rating (suction/discharge): -/PN 10
Accessory DAC 80/80V+KAF 116-2" EN (P)		Accessory code 9001.032
Note: Accessory must be ordered separately		

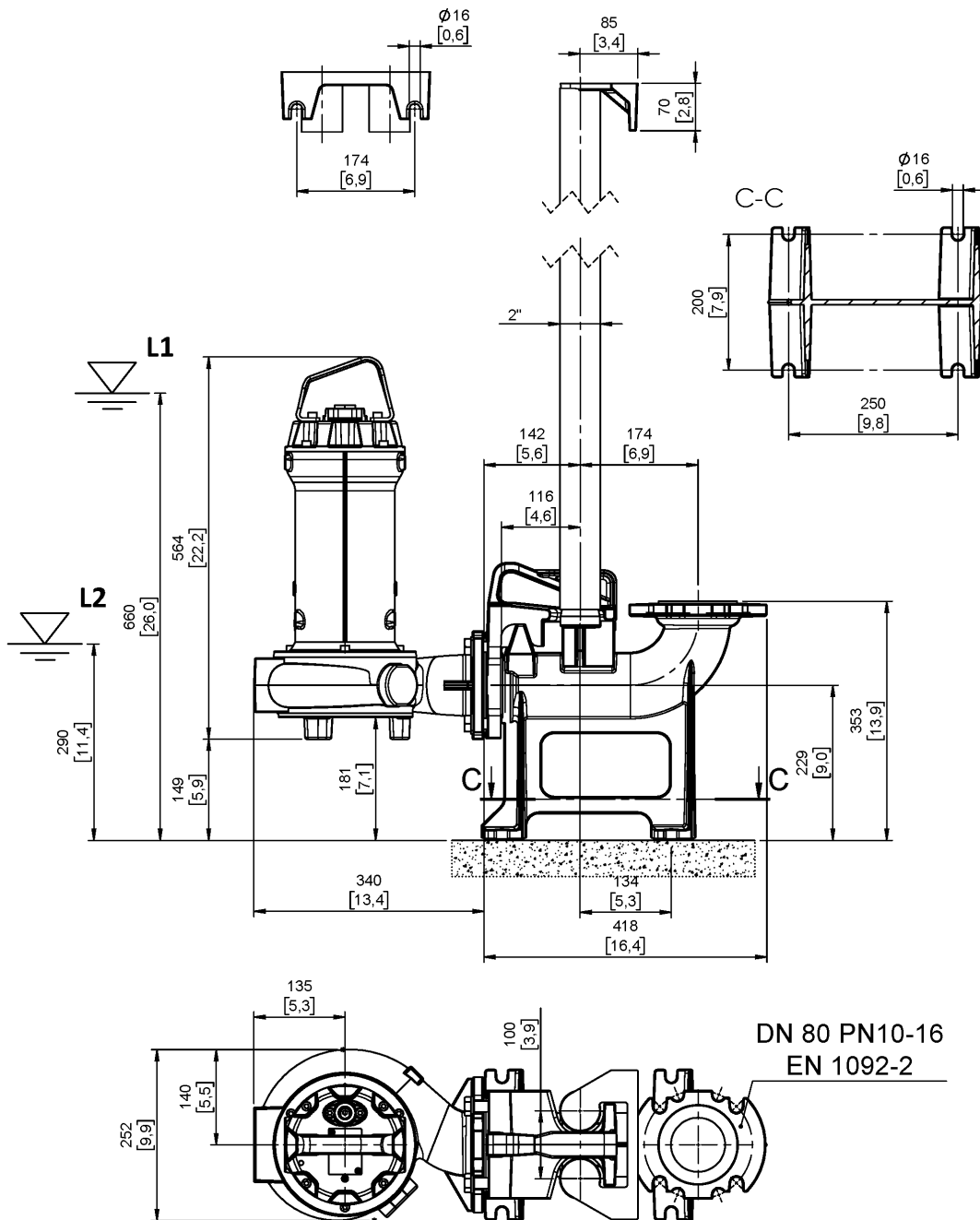

[mm
[inch]

L1: Minimum operating level for continuous use

L2: Minimum operating level for discontinuous use (excluding -EX/FM models)