



better together

Data sheet

GRG 250/2/G40H A0AT5



GREY
series

Technical specification

3~ 50 Hz

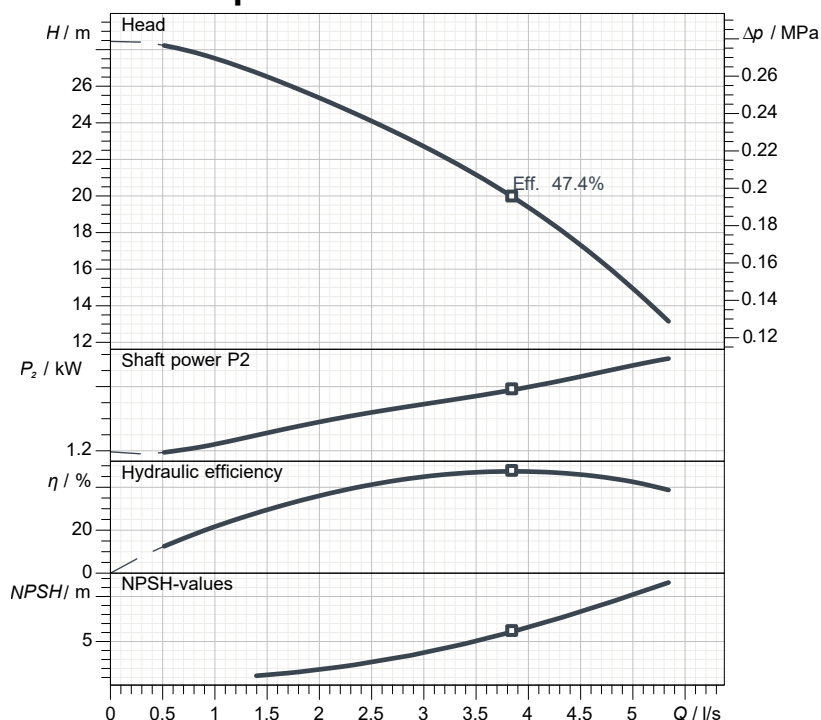

Characteristic curves according to UNI EN ISO 9906:2012
P2 < 10kW: paragraph 4.4.2
10kW < P2 < 100kW: Grade 3B
P2 > 100kW: Grade 2B

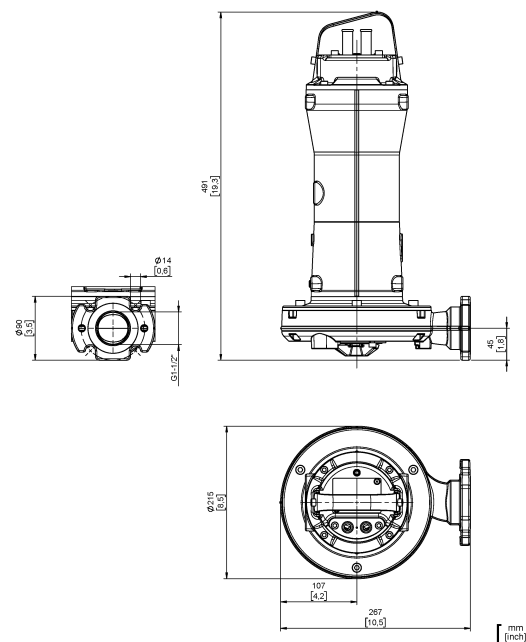

Pump

Series	GREY series
Pump name	GRG 250/2/G40H A0AT5
Configuration	NGTSB51040N00EX
Standard	ATEX 2014/34/EU
ATEX mark	II 2G Ex db IIB T4 Gb Ex h IIB T4 Gb

Operating limits (standard pumps)

Max. ambient temperature	40 °C
Max. density treated liquid	1100 kg/m ³
pH treated liquid	6 ÷ 14
Max. start per hour (equally distributed)	30
Wet/dry use	WET
Max. acoustic pressure level	70 dB
Operating mode	S1 - Continuous use

Motor data

Rated voltage	400 V
Frequency	50 Hz
Motor phases	3~
Number of poles	2
Rated power P2	1.80 kW
Incoming power P1	2.19 kW
Rated current	3.7 A
rpm	2794 1/min
Efficiency	82.3 %
cos φ	0.853
Rated torque	6.2 Nm
Start	Direct starting
Starting current	21.9 A
Degree of protection	IP 68
Insulation class	H
Capacitor	
Starting Capacitor	

Construction materials

Case	Cast iron EN-GJL 250
Shaft	Stainless steel AISI 431
Hydraulic	Cast iron EN-GJL 250
Impeller	Cast iron EN-GJL 250
Painting/Coating	Bi-epoxy 200 μm sea water
Screws	Stainless steel - Class A2-70
Gaskets	NBR
Cutter	Chromium steel - X102 CrMo17 KU
Cutting disk	Chromium steel - X102 CrMo17 KU

Construction features

Cooling system	No cooling jacket
Main cable	4G1+3x1
Cable length	10 mt
Mechanical seals	2 in silicon carbide (2SiC)
Additional drilling	-
Weight*	32 kg
Electrical variant	Thermal protection and leakage sensor

* cable and fixing system excluded

Hydraulic

Free passage	0 mm
Impeller type	Open channel impeller with grinder system
Max. hydraulic efficiency	47.4 %
Suction	
Discharge	DN 32 - G 1"1/2 EN 1092-2



better together

Data sheet GRG 250/2/G40H A0AT5



GREY
series

Pump performance curves

3~ 50 Hz

Impeller type Open channel impeller with grinder system		Free passage 0 mm	Discharge DN 32 - G 1"1/2	Suction	
DUTY POINT					
Flow	Head	Shaft power P2	Hydraulic efficiency	Density 998.3 kg/m ³	Viscosity 1.005 mm ² /s

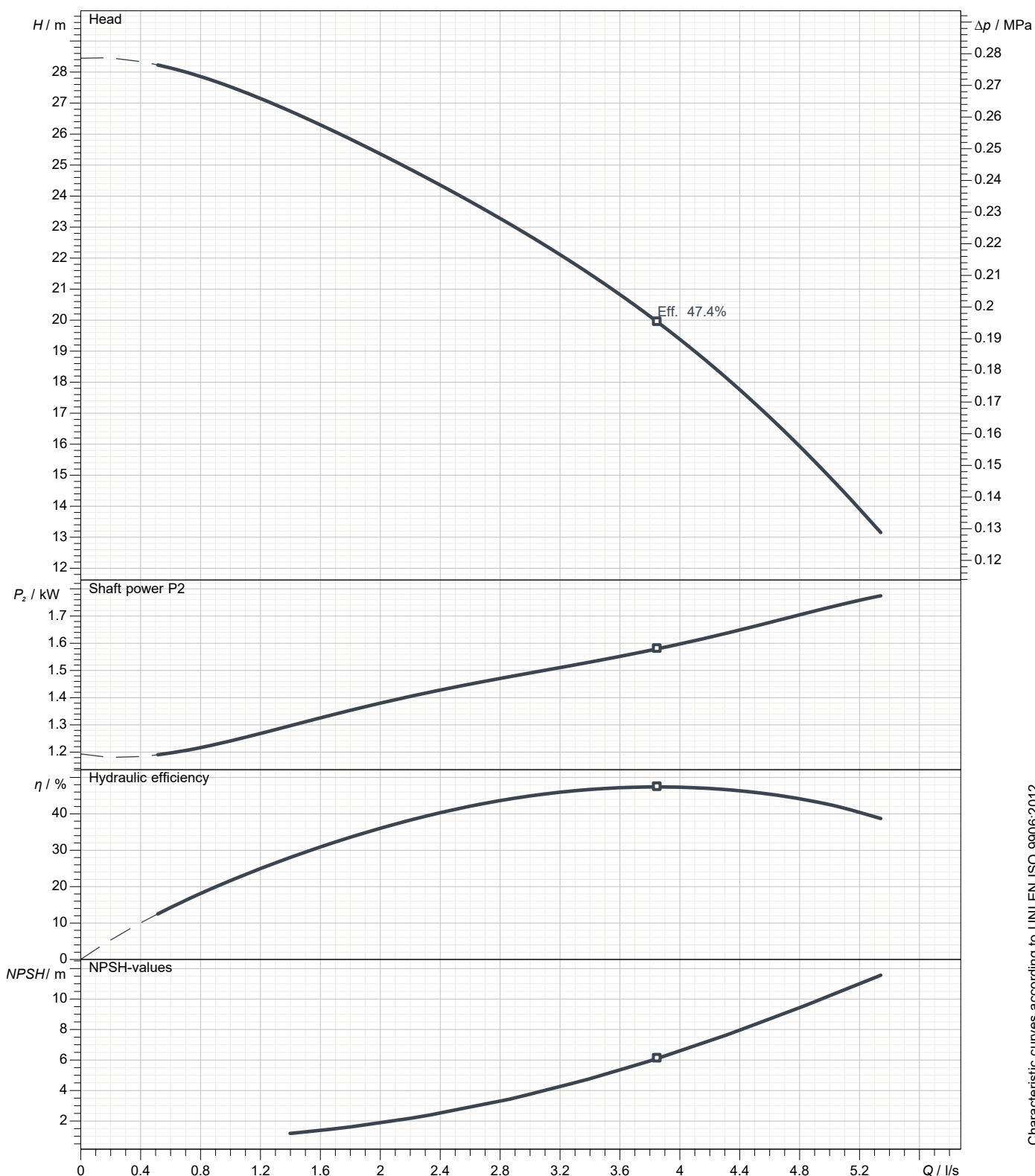

Characteristic curves according to UNI EN ISO 9906:2012
 P2<10kW: paragraph 4.4.2
 10kW<P2<100kW: Grade 3B
 P2>100kW: Grade 2B



better together

Data sheet

GRG 250/2/G40H A0AT5



GREY series

Dimensional drawing

3~ 50 Hz

Installation type Installation with bottom coupling device - Horizontal/vertical outlet		
Wet/dry use WET	Drilling variant N	Flushing valve - drilling -
Discharge DN 32 - G 1"1/2 EN 1092-2	Suction	Pressure rating (suction/discharge): PN 6
Accessory DAC 32-50/G50H-G50V+KAF 3/4" EN (P)		Accessory code 9028.010
Note: Accessory must be ordered separately		

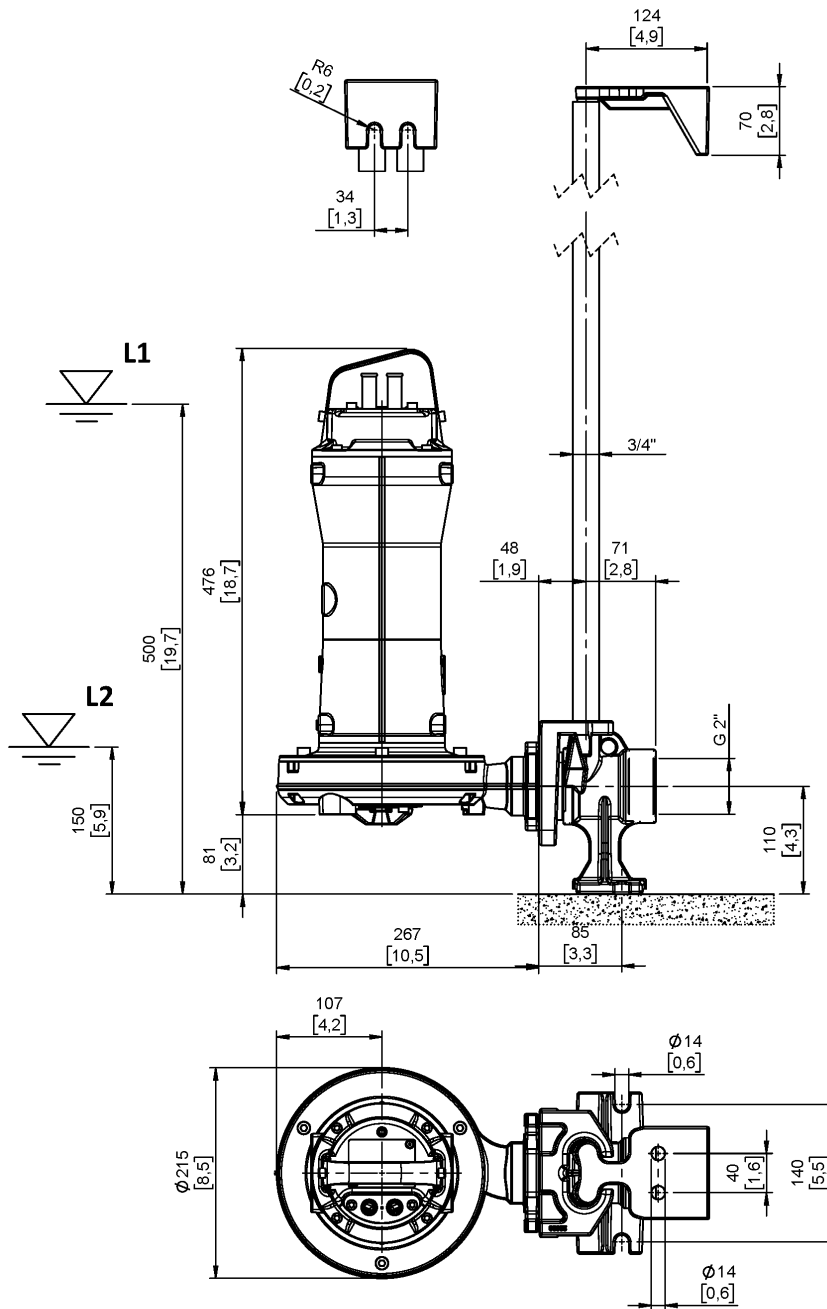

[mm
[inch]

L1: Minimum operating level for continuous use

L2: Minimum operating level for discontinuous use (excluding -EX/FM models)